

Technical Data Sheet	<b>Gas booster</b>	<b>DLE 75</b> Double acting, single stage, single air drive head
----------------------	--------------------	---

### Available DLE series

- Single acting, single stage, single air drive head
- Double acting, single stage, single air drive head
- Double acting, single stage, double air drive head
- Single acting, two stages, single air drive head
- Single acting, two stages, double air drive head

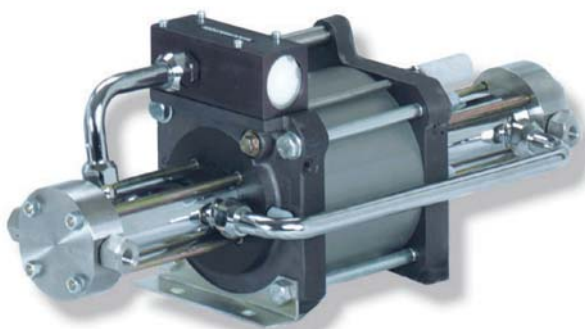

### Technical Data:

Air drive pressure pL:	1-10 bar / 14.5—145 psi
Pressure ratio i:	1:75
Compression ratio	1:20
Minimum suction pressure pA:	35
Maximum suction pressure pA:	1,500 bar
Maximum outlet pressure pB:	1,500 bar
Displacement volume/double stroke	50 cm <sup>3</sup>
Maximum cycles	130 / min
Stall pressure	PB = i * pL + pA

### Standard connections

Air drive	3/4 BSP
DLE 75 (-GG)	Inlet/Outlet: 1/4BSP
Maximum Operating Temperature	100°C
Net Weight	18 kg

Pressure and flow performances, please see enclosed graph.

<b>Materials of construction hp section DLE 75:</b>	Standard seal package	PTFE, Viton
	Compressor head	1.4305
	HP cylinder	1.4057
	HP piston	1.4305
	Fittings	1.4305
	Balls	1.4034
	Springs	X12CrNi177
<b>Approximate Dimensions:</b>	Length	620 mm
	Width	181 mm
	Height	233 mm
<b>Available Options:</b>	Inert gas service (standard)	DLE 75 (-GG) (materials of construction as above indicated)
	Oxygen service	DLE 75-GG- <b>S</b> parts especially oxygen cleaned
	CO <sub>2</sub> service	DLE 75-GG- <b>C</b> Seal package: PTFE, NBR
	Other inlet and outlet ports	Order codes
	Inlet: 9/16-18UNF Outlet: 9/16-18UNF	DLE 75- <b>UU</b>
	Inlet: 1/4NPT Outlet: 1/4NPT	DLE 75- <b>NN</b>
<b>Available Accessories</b>	Air control units for DLE series with filter pressure regulator, control pressure gauge and shut off valve:	DLE 75 with <b>C2</b>
	To protect the booster against excessive outlet pressures or to limit the outlet pressure, a safety valve can be fitted to the air control unit in the air drive line:	DLE 75 with <b>C2/SVair</b> (The required outlet pressure has to be indicated.)
	Special seal material to handle special gases on request.	

### Please consult factory for more information.

All technical and dimensional information subject to change. All General Terms and Conditions of sale, including limitations of our liability, apply to all products and services sold

MAXIMATOR  
 Maßzeichnung / Dimension drawing  
 Typ / type: DLE 15, DLE 30, DLE 75

